

Headquarters & Factory

296, Seunggicheon-ro, Namdong-gu,
Incheon 21634, Republic of Korea

Tel : +82. 32. 818. 0105

Fax : +82. 32. 818. 0109

E-mail : handol@handolpumps.com

Website : www.handolpumps.com

European Headquarters & Factory

IT Safco Engineering GmbH
Sandfeld 1, 2100 Stetten, Austria

Tel : +43. 2262. 22220-0

Fax : +43. 2262. 22220-24

E-mail : office@safco.co.at



PRESIDENT GREETINGS

HANDOL PUMPS LIMITED is a leading company specialized in manufacturing various API 610 Centrifugal Pumps.

Since HANDOL PUMPS was established in 1993, we have developed and manufactured a wide range of centrifugal pumps for diverse applications in Power Generation, Oil & Gas, Petrochemical and many other industries.

Our products that have been exported to about 30 countries are internationally reputed for their technical excellence.

We are the cornerstone that leads the development of the pump technology.



PRESIDENT

Bong-joo Lee

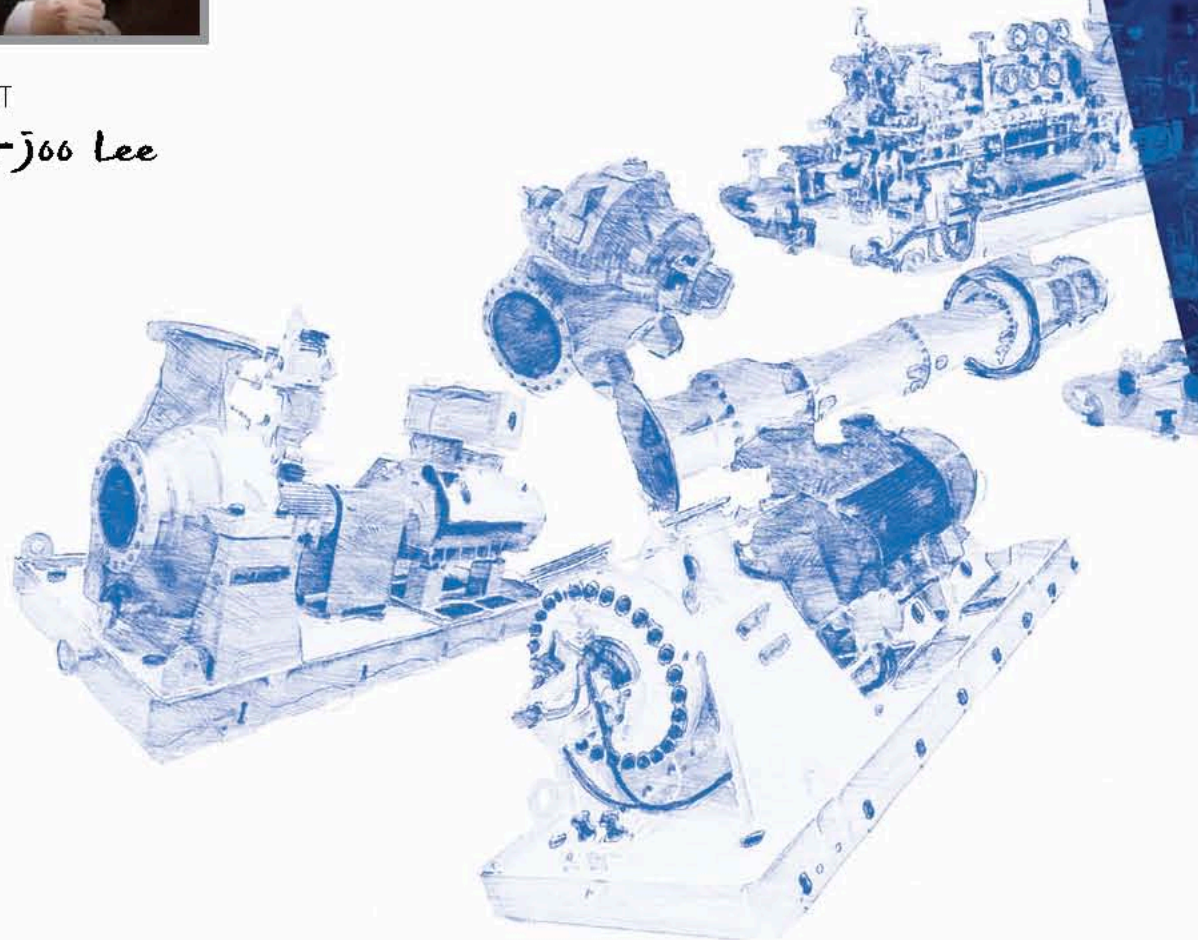

HISTORY

- 1993. 03 HANDOL PUMPS LIMITED was founded in Incheon, Korea.
- 1995. 10 Headquarters including the factory moved to Namdong Industrial Complex in Incheon, Korea.
- 1996. 11 HANDOL's High Pressure Multistage Pump (120bar grade) was approved as Excellent Korean Technology by Korean Government.
- 1997. 05 Designated as a Promising Advanced Technology Enterprise.
- 1997. 05 Registered as a pump supplier for nuclear power plants of Korea Electric Power Corporation
- 1997. 11 Awarded as the Developer of High Pressure Boiler Feed Pumps for Co-generation Power Plant by Government.
- 1998. 12 ISO 9001 Certification.
- 2004. 04 CE Certification.
- 2000. 11 Opened HANDOL R&D Center.
- 2001. 03 Registered as a Pump supplier for Korea Hydro & Nuclear Power Company
- 2010. 05 Permit to Use Certification of Gospromnadzor, Belarus.
- 2010. 07 CE - ATEX Certification.
- 2010. 11 Awarded the 1 Million dollar Export Tower Award on the 47th Trade Day.
- 2010. 11 Awarded Prize from Ministry of Knowledge Economy.
- 2011. 06 ISO 14001 Certification.
- 2011. 08 GOST R of Russia Certification.
- 2011. 12 Permit to Use Certification of Rostekhnadzor, Russia.
- 2012. 05 Completed New Headquarters building in the current location, Namdong Indus Park in Incheon, Korea
- 2012. 09 Awarded the KOTRA GLOBAL BRAND 2012
- 2012. 12 Awarded the 3 Million dollar Export Tower Award on the 49th Trade Day.
- 2013. 01 Completed New Factory in the current location, Namdong Indus Park in Incheon, Korea.
- 2015. 04 OHSAS 18001 Certification.
- 2015. 12 TRCU 010 and 012 Certification.
- 2016. 12 Korea World-class Product Award
- 2017. 10 Awarded Prize from Ministry of Trade, Industry and Energy.



America

USA, Colombia,
Brazil, Chile

Africa

Algeria, Egypt, Ghana, Libya, Sudan, South
Sudan

Europe

Austria, Belarus, Bulgaria,
Croatia, Russia, Serbia,

Asia

Bangladesh, China, India, Indonesia, Iran, Iraq,
Indonesia, Japan, Korea, Malaysia, Qatar, Saudi Arabia,
Singapore, Taiwan, Thailand, U.A.E, Vietnam,

CERTIFICATES



ISO 9001



ISO 14001



OHSAS 18001



CE - ATEX (OH2, OH3)



CE - ATEX (BB2 Single-stage)



CE - ATEX (BB2 Two-stage)

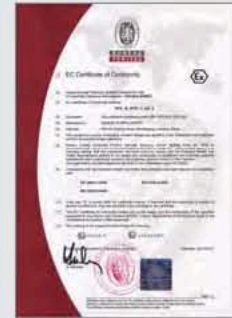

CE - ATEX (BB3)



CE - ATEX (BB4)

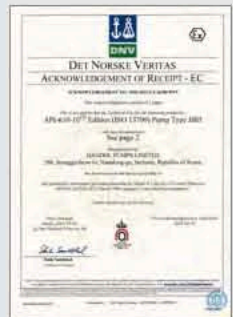

CE - ATEX (BB5)



CE - ATEX (VS11)



CE - ATEX (VS4)



CE - ATEX (VS6)

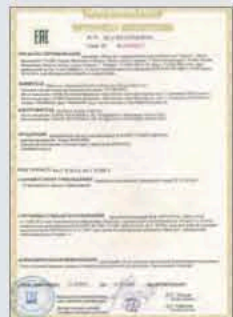

TR CU 010



TR CU 012



Korea World-class Product Award

MAJOR MODELS SEGMENT MATRIX

Product Types	Pump Model	API 610 Pump Type	Oil & Gas Up-and Midstream	Oil & Gas Downstream	Power Generation	Water & Wastewater	Chemical	Pulp & Paper
Axially split pumps	DSA	BB1	●	●	●	●		
	DSH / DCN	BB1			●	●	●	●
	ASM	BB3	●	●	●	●	●	●
	SM / SMB	BB3	●	●	●	●	●	●
Double-casing pumps	BTN	BB5	●	●	●			
Ring section pumps	STN	BB4	●		●	●	●	●
	STN-RO	BB4				●		
	TMN / TMS	BB4			●	●	●	●
Two-stage pumps	RT	BB2	●	●	●		●	
Single-stage pumps	RDA	BB2	●	●	●		●	
	IPH	OH1	●	●	●	●	●	●
	HPP	OH1		●	●	●	●	●
	HPH	OH2			●			
	AH	OH2	●	●	●		●	
	LNA	OH2	●	●	●		●	
	APVF	OH3	●	●			●	
	HAF						●	
Vertical pumps	VTH	VS1	●	●	●	●	●	●
	HPV	VS4	●	●	●	●	●	●
	VLN	VS4	●	●			●	
	VW	VS4	●	●	●	●	●	
	VCH	VS6	●	●	●	●	●	●
	VCTM	VS6	●	●	●	●	●	●

DSA

API 610 / ISO 13709 Type BB1
Axially Split Single-Stage Double Suction Pump

 Capacities
Up to 15000 m3/h

 Pressures
Up to 25 bar

 Temperatures
Up to 150 °C

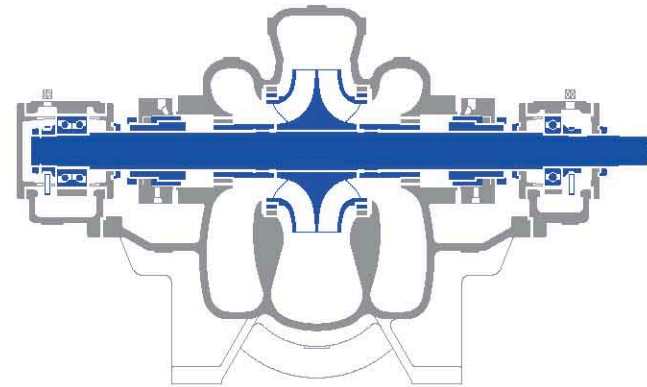

APPLICATIONS

- Hydrocarbon and Water Transfer
- Petroleum Refining, Production and Distribution
- Petrochemical and Heavy Duty Chemical Processing
- Hydrocarbon and Water Pipeline
- Power Generation
- Gas Scrubbing
- Cooling Water

FEATURES AND BENEFITS

- Full compliance with API 610 / ISO 13709, latest edition.
- For larger size, Double Volute Casing minimizes radial thrust, thus reduces shaft deflection.
- Double Suction Impeller minimizes axial thrust and allows low NPSHR and highly efficient, vibration-free operation.
- Robust Foot-Mounted resists external forces and vibration.
- Renewable Wear Rings ensure hydraulic stability and efficient operation.
- Large Diameter Shaft and Short Bearing Span minimize deflection.

ASM

API 610 / ISO 13709 Type BB3
Axially Split Double Volute Type Multistage Pump

 Capacities
Up to 2000 m3/h

 Pressures
Up to 200 bar

 Temperatures
Up to 200 °C

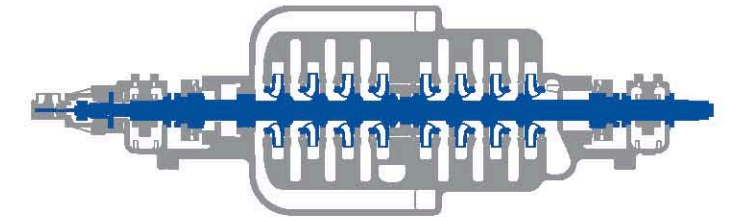

APPLICATIONS

- Pipeline
- Boiler Feed
- Water Injection
- Process Charge
- Descaling
- Mine Dewatering
- Power Recovery
- Reverse Osmosis Feed

FEATURES AND BENEFITS

- Full compliance with API 610 / ISO 13709, latest edition.
- Double Volute Hydraulic Passages for radial thrust balance and Opposed Impeller Mounted for axial thrust balance.
- Double Volute, Axially Split casing with integral compact crossovers minimizes flow losses, maximize efficiency.
- Precision Cast Impellers balanced dynamically for the maximum hydraulic efficiency.
- Double Suction First-Stage Impeller [ASM-D] is available for lower NPSHR.
- Centerline-Mounted for superior alignment.
- API 610 Seal Chambers accept various range of API 682 sealing options.

DSH | DCN

Axially Split Single-Stage Double Suction Pump

 Capacities
Up to 15000 m3/h

 Pressures
Up to 25 bar

 Temperatures
Up to 150 °C

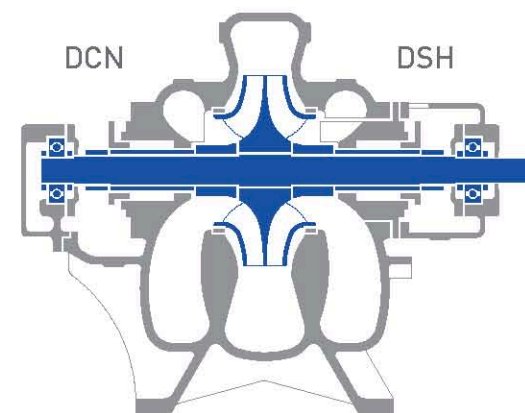

APPLICATIONS

- Industrial Process
- Water Intake, Distribution, Boosting, Circulation, Drainage, Fire-Fighting
- Seawater Desalination
- District Heating and Cooling
- Pipe-Line Boosting
- Fire-Fighting

FEATURES AND BENEFITS

- For larger size, Double Volute Casing minimizes radial thrust, thus reduces shaft deflection.
- Double Suction Impeller minimizes axial thrust and allows low NPSHR and highly efficient, vibration-free operation.
- Robust Foot-Mounted resists external forces and vibration.
- Renewable Wear Rings ensure hydraulic stability and efficient operation.
- Large Diameter Shaft and Short Bearing Span minimize deflection.

SM | SMB

API 610 / ISO 13709 Type BB3
Axially Split Diffuser Type Multistage Pump

 Capacities
Up to 1800 m3/h

 Pressures
Up to 220 bar

 Temperatures
Up to 200 °C

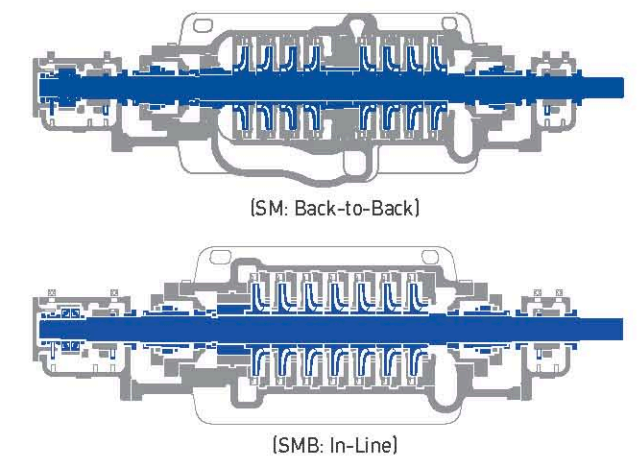

APPLICATIONS

- Pipeline
- Boiler Feed
- Water Injection
- Process Charge
- Descaling
- Mine Dewatering
- Power Recovery
- Reverse Osmosis Feed

FEATURES AND BENEFITS

- Full compliance with API 610 / ISO 13709, latest edition.
- Radial and axial thrust balance is assured by Diffuser Design and Balance Piston or Impeller Arrangement.
- Precision Cast Impellers and diffusers for the maximum hydraulic efficiency.
- Two Types of Impeller Arrangement.
 - SM : Back-to-Back
 - SMB : In-Line
- Diffusers provide smooth flow transition and reduces hydraulic losses.
- Centerline-Mounted for superior alignment.
- API 610 Seal Chambers accept various range of API 682 sealing options.

BTN

API 610 / ISO 13709 Type BB5
Double-Casing (Barrel) Radially Split Multistage Pump

 Capacities
Up to 900 m³/h

 Pressures
Up to 220 bar

 Temperatures
Up to 450 °C

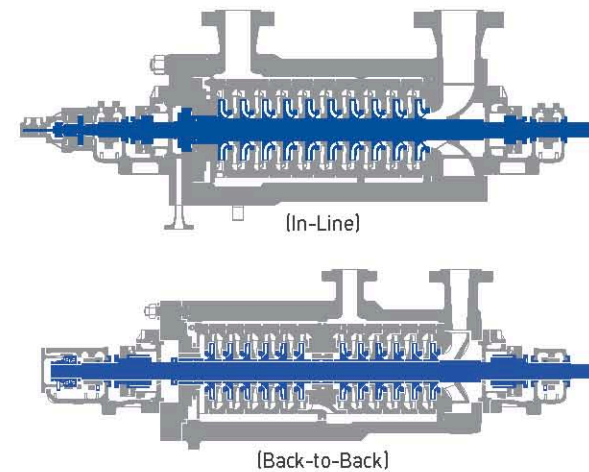

APPLICATIONS

- Pipeline
- Boiler Feed
- Amine, Ethylene Feed
- Water Injection
- Hydrocarbon Charge
- Acid Gas Reinjection
- Hydraulic Power Recovery Turbine

FEATURES AND BENEFITS

- Full compliance with API 610 / ISO 13709, latest edition.
- Double-Casing Construction features a simple cylindrical outer casing and cover with only one circular joint enclosing the inner casing.
- Centerline-Mounted absorbs high forces and moments.
- Precision Cast Impellers and diffusers for maximum hydraulic efficiency.
- Double Suction First-Stage Impeller is available for lower NPSHR. (BTN-D)
- Back-to-Back (Opposed) arrangement is available for Extreme Pressures.
- API 610 Seal Chambers accept various range of API 682 sealing options.

STN-RO

RO Ring Section Type Multistage Pump

 Capacities
Up to 1200 m³/h

 Pressures
Up to 100 bar

 Temperatures
Up to 120 °C

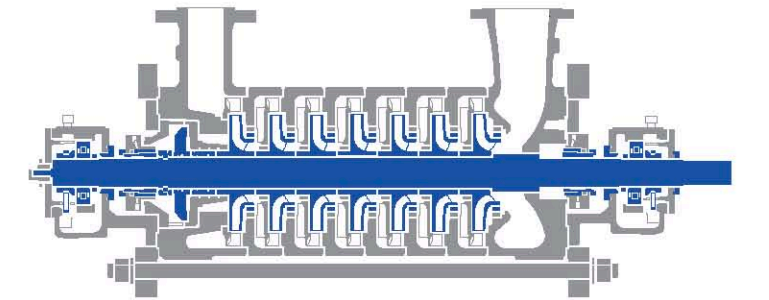

APPLICATIONS

- High Pressure RO feed
- Water Transmission
- Raw Water Transfer
- Clean water pumping stations
- Any other high pressure application with clean liquids and low temperature

FEATURES AND BENEFITS

- Oil Lubricated Anti-friction Bearings for long-life performance.
- High Efficiency and Low NPSH Impellers.
- Precision Cast Impellers and diffusers for maximum hydraulic efficiency.
- Flanges can be installed side or top position as per customer convenience.
- Compound Material Wear Rings for min. flow losses and reliable operation.
- Duplex Stainless Steel or Super Duplex Stainless Steel for all wetted pump parts.
- Total Axial Thrust is perfectly balanced by a Balance Disk.
- Cartridge Seals assure easy maintenance and precise seal face setting.

STN

Ring Section Type High Pressure
Multistage Pump

 Capacities
Up to 1000 m³/h

 Pressures
Up to 220 bar

 Temperatures
Up to 200 °C

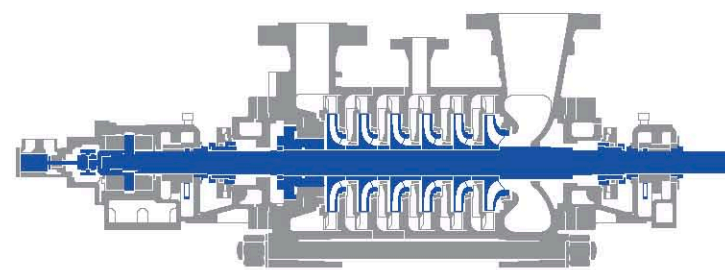

APPLICATIONS

- Boiler Feed
- Condensate Extraction Service in Power Plants
- Descaling
- High Pressure Water in the General Industry

FEATURES AND BENEFITS

- Also manufactured as API 610 / ISO 13709 Type BB4, latest edition.
- Centerline-Mounted and heavy duty design.
- Precision Cast Impellers and diffusers for maximum hydraulic efficiency.
- Double Suction First-Stage Impeller is available for lower NPSHR. (STN-D)
- Total Axial Thrust is perfectly balanced by a Balance Disk. Also Balance Piston (Drum) System is available.
- Ring Oil Lubricated Sleeve Type and Babbitt Lined Bearings are standard. Ball Bearing or Pivot Shoe type for Balance Piston type and API 610 BB4.

TMN | TMS

Ring Section Type Medium Pressure
Multistage Pump

 Capacities
Up to 1800 m³/h

 Pressures
Up to 60 bar

 Temperatures
Up to 200 °C

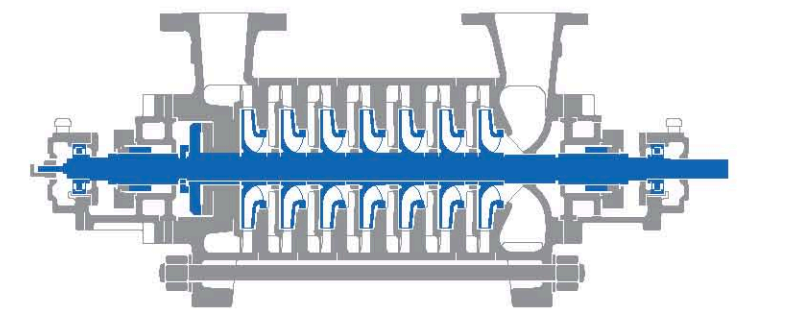

APPLICATIONS

- Boiler Feed
- Water Processing
- Boosting
- Mine Dewatering
- Fire-Fighting
- General Industries

FEATURES AND BENEFITS

- Also manufactured as API 610 / ISO 13709 Type BB4, latest edition.
- Foot-Mounted and Heavy Duty Design.
- Precision Cast Impeller balanced dynamically for maximum hydraulic efficiency.
- Double Suction First-Stage Impeller is available for lower NPSHR.
- Flanges can be installed side or top position as per customer convenience.
- Total Axial Thrust is perfectly balanced by a Balance Disk. Also Balance Piston (Drum) System is available.
- Roller Bearings on both sides and separable bearings facilitate assembly and dismantling.
- Ring Oil Lubricated Sleeve Type and Babbitt Lined Bearings are standard for TMS 200 and larger ones.

RT

API 610 / ISO 13709 Type BB2
Radially Split Two-Stage Pump

 Capacities
Up to 1700 m³/h

 Pressures
Up to 75 bar

 Temperatures
Up to 450 °C

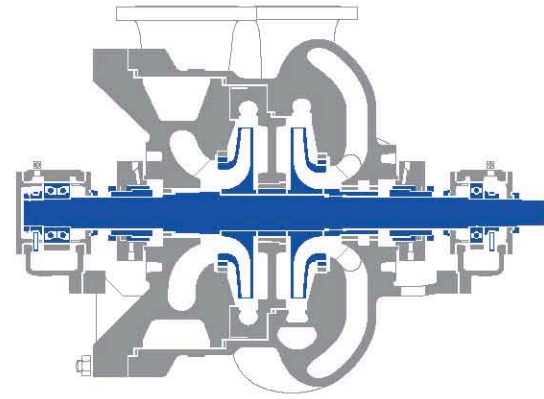

APPLICATIONS

- Petroleum Refining, Production and Distribution
- Petrochemical and Heavy Duty Chemical Processing
- Liquefied Gas Industry Services
- Boiler Feed
- Heavy-Duty Utility Services

FEATURES AND BENEFITS

- Full compliance with API 610 / ISO 13709, latest edition.
- Centerline-Mounted Heavy Radially Split Casing.
- Opposed Impeller Arrangement for low axial forces.
- Double Suction First-Stage Impeller is available for lower NPSHR (RT-D).
- Heavy Duty Shaft for low shaft deflection.
- Tapered Shaft End for easy seal maintenance and coupling removal.
- API 610 Seal Chambers accept various range of API 682 sealing options.

IPH

ISO 2858 / 5199 Upgraded Medium Duty
Foot-Mounted Single-Stage Overhung Pump

 Capacities
Up to 4800 m³/h

 Pressures
Up to 25 bar

 Temperatures
From -25 to 300 °C

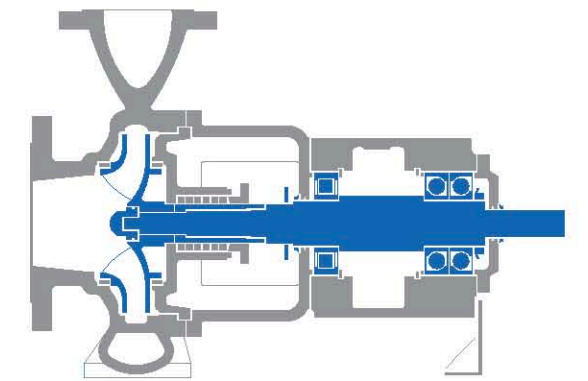

APPLICATIONS

- Chemicals
- Seawater Desalination
- Petrochemicals
- Refineries
- Pulp and Paper
- Food and Beverages
- Sugar Refineries

FEATURES AND BENEFITS

- Meets technical requirements to ISO 5199 and Dimensions & ratings to ISO 2858.
- Foot-Mounted and Upgraded Medium Duty Design.
- Back Pull-Out Design permits easy maintenance.
- Improved Shaft Design reduces the shaft deflection and increases shaft and seal lifetime.
- Back-to-Back Angular Contact Ball Bearings protect against rotor shuttling.
- Heating Jacket and Cooling Jacket are available.
- Also manufactured as API 610 / ISO 13709 Type OH1, latest edition.

RDA

API 610 / ISO 13709 Type BB2
Radially Split Single-Stage Double Suction Pump

 Capacities
Up to 4000 m³/h

 Pressures
Up to 50 bar

 Temperatures
Up to 450 °C

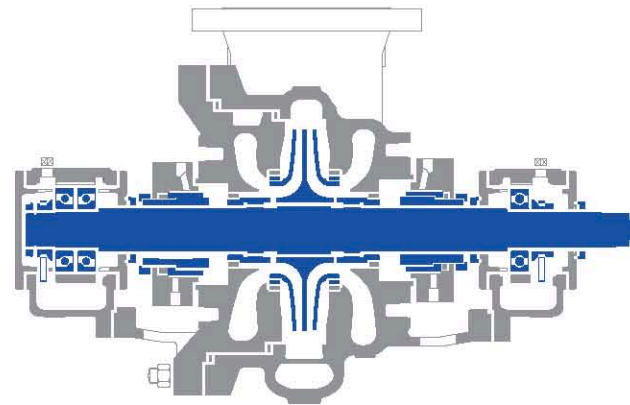

APPLICATIONS

- Petroleum Refining, Production and Distribution
- Petrochemical and Heavy Duty Chemical Processing
- Liquefied Gas Industry Services
- Boiler Feed Boosting
- Treated Sea Water

FEATURES AND BENEFITS

- Full compliance with API 610 / ISO 13709, latest edition.
- Centerline-Mounted Heavy Radially Split Casing.
- Double Suction Impeller allows to operate in lower NPSHR.
- Double Volute Casing for high capacity for min. radial loads on the rotor.
- Heavy Duty Shaft for min. shaft deflection and longer bearing & seal lifetime.
- API 610 Seal Chambers accept various range of API 682 sealing options.
- Tapered Shaft End for easy seal maintenance and coupling removal.
- Ring Oil Lubricated Radial Ball and Ball Thrust Bearing are Standard. Ball or Tilting Pad Bearing as thrust bearing along with sleeve babbit lined radial bearing.

HPP

End Suction Single-Stage Open Impeller
Process Pump

 Capacities
Up to 4800 m³/h

 Pressures
Up to 25 bar

 Temperatures
Up to 180 °C

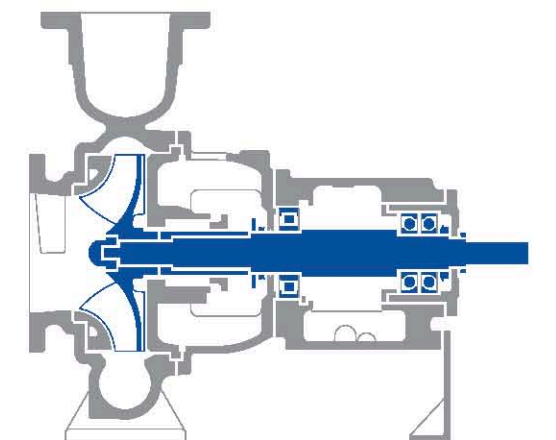

APPLICATIONS

- Pulp and Paper
- Chemicals
- Waste Water / Sewage Treatment
- Food and Beverages
- Sugar

FEATURES AND BENEFITS

- Foot-Mounted and Heavy Duty Design.
- Back Pull-Out Design permits easy maintenance.
- Open Impeller and external adjusting equipment.
- Renewable Front Wear Plate for longer casing lifetime.
- Shaft and bearings are dimensioned for minimum shaft deflection and maximum bearing and seal lifetime.

HPH

Hot Water and Boiler Circulating Pump

 Capacities
Up to 1800 m³/h

 Pressures
Up to 110 bar

 Temperatures
Up to 320 °C

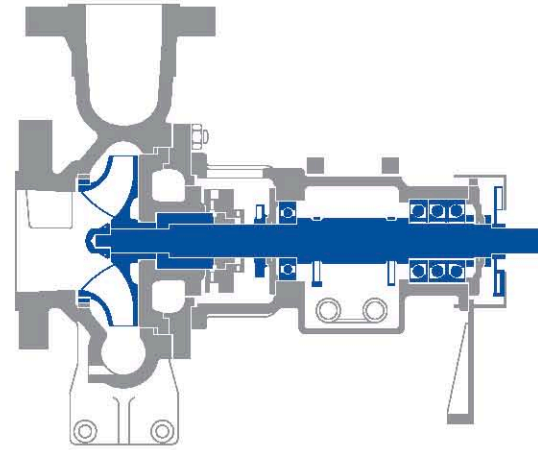

APPLICATIONS

- Forced Circulation Boilers
- High Pressure Hot Water Generation Plants

FEATURES AND BENEFITS

- Centerline-Mounted and Heavy Duty Design.
- Back Pull-Out Design permits easy maintenance.
- Axial thrust balance by Anti-Friction Bearings

LNA

API 610 / ISO 13709 Type OH2
Centerline-Mounted Low Flow High Head Process Pump

 Capacities
Up to 50 m³/h

 Pressures
Up to 50 bar

 Temperatures
Up to 450 °C

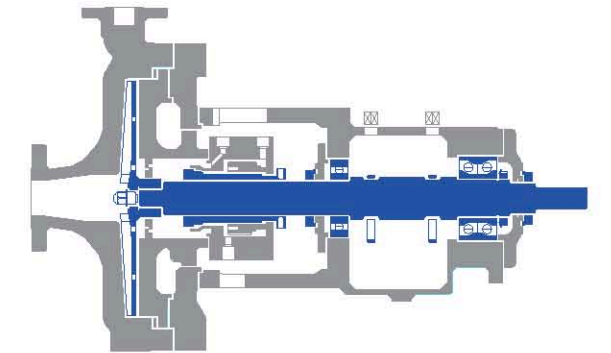

APPLICATIONS

- Petroleum Refining
- Petrochemicals
- Gas Processing
- Nitrogenous Fertilizer
- Boiler Feed / Condensate

FEATURES AND BENEFITS

- Meets or exceeds the requirements of API 610 / ISO 13709, latest edition.
- Multiple Radial Blade Impeller provides superior hydraulic fits at low flows.
- Multiple balance holes provide increased head with high efficiency and is more reliable in balancing axial thrust compared to Pump-out vane designs.
- Machined Casing ensures BEP fits for any given set of hydraulics.
- Centerline-Mounted Construction for API 610 nozzle requirements.
- Back Pull-Out Design permits easy maintenance.
- Shaft Design for min. shaft deflection and max. shaft and seal lifetime.
- API 610 Seal Chambers accept various range of API 682 sealing options.

AH

API 610 / ISO 13709 Type OH2
Centerline-Mounted Single-Stage Overhung Pump

 Capacities
Up to 4000 m³/h

 Pressures
Up to 50 bar

 Temperatures
From -100 to 450 °C

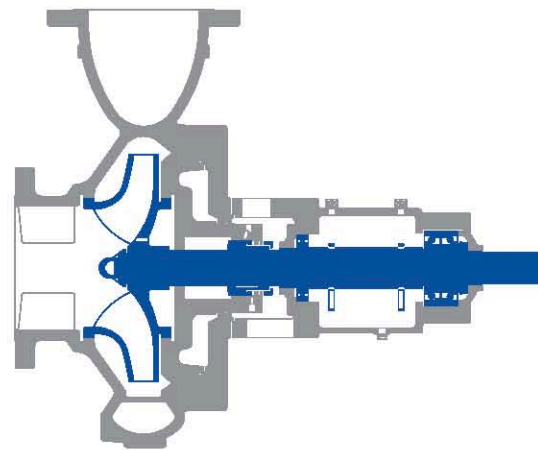

APPLICATIONS

- Petroleum Refining, Production and Distribution
- Petrochemical and Heavy Duty Chemical Processing
- Gas Industry Services
- Boiler Circulation and other High Temperature Services
- Water and General Industrial Services
- Cryogenic Services

FEATURES AND BENEFITS

- Full compliance with API 610 / ISO 13709, latest edition.
- Heavy Duty Centerline-Mounted Construction for API 610 nozzles.
- Back Pull-Out Design permits easy maintenance.
- Double Volute for low radial thrust depending on size.
- A Special Impeller or an additional inducer for lower NPSHR.
- Shaft Design for min. shaft deflection and max. shaft and seal lifetime.
- Ring Oil Lubricated Radial Ball and Back-to-Back Duplex, Single Row, 40° Angular Contact Ball Thrust Bearings are Standard.
- API 610 Seal Chambers accept various range of API 682 sealing options.

APVF

API 610 / ISO 13709 Type OH3
Vertical In-Line Process Pump

 Capacities
Up to 1400 m³/h

 Pressures
Up to 50 bar

 Temperatures
Up to 340 °C

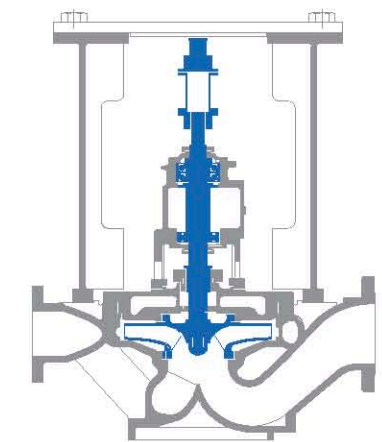

APPLICATIONS

- Petroleum Refineries
- Petrochemicals
- Gas Processing
- Bitumen Processing
- Offshore Oil Production Platforms
- Floating Production, Storage and Offloading (FPSO) Units
- Cryogenic Services

FEATURES AND BENEFITS

- Full compliance with API 610 / ISO 13709, latest edition.
- In-Line permits minimum installation space and costs.
- Back Pull-Out Design permits easy maintenance.
- Bearing Bracket carries pump loads.
- Field Alignment not required.
- API 610 Seal Chambers accept various range of API 682 sealing options.

HAF

Axial Flow (Propeller) Pump

Capacities
Up to 11500 m³/h

Pressures
Up to 6 bar

Temperatures
Up to 200 °C

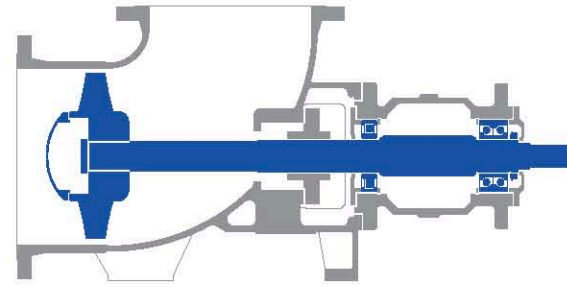

HPV | VW | NCV NFV | VLN

Vertical Sump Pump

Capacities
Up to 1000 m³/h

Pressures
Up to 20 bar

Temperatures
Up to 350 °C

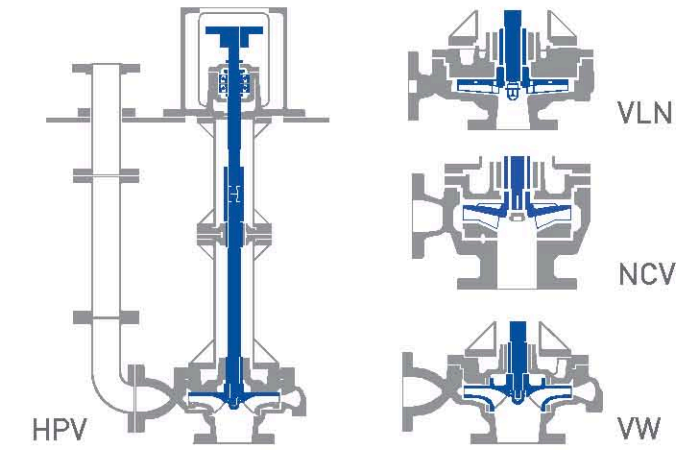

APPLICATIONS

- Biogas Plants
- Evaporation and Crystallization Plants
- Chemical Industry / Process Engineering
- Waste Water / Clarification Engineering
- Desalination Plants
- De-Sulphurization

FEATURES AND BENEFITS

- High Efficiency and Maximum Reliability.
- Easy installation and Maintenance.
- Pump Drive Directly Coupled.
- End Suction Configuration is standard and top suction is also available.
- Shaft sealing in a variety of designs and materials.
- Higher Flows upon request.

APPLICATIONS

- Petrochemical Processing
- Chemical Processing
- Refinery Offsites
- Drainage
- Industrial Sump Wastes
- Industrial Processing
- Tank Unloading
- Molten Sulfur

FEATURES AND BENEFITS

- Also manufactured as API 610 / ISO 13709 Type VS4, latest edition.
- Multiple Hydraulic Designs: Semi-Open Impeller (HPV), Enclosed Impeller (VW), Channel Impeller (NCV), Recessed/Vortex Impeller (NFV), Radial Vane Impeller (VLN).
- Radial Plain Bearings lubricated by grease or pumped liquid.
- Thrust Anti-Friction Bearings lubricated by grease or oil.
- Packing or Mechanical Seal is used upon request.

VTH

Vertical Turbine Pump / Vertical Mixed Flow Pump

Capacities
Up to 15000 m³/h

Pressures
Up to 40 bar

Temperatures
Up to 200 °C

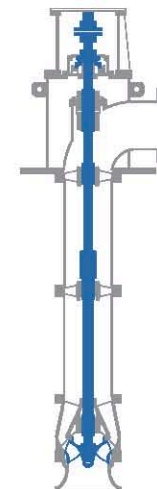

VCH | VCTM

Vertical Double-Casing (Can) Diffuser Pump

Axial Diffuser Hydraulics (VCH)

Capacities
Up to 3500 m³/h

Pressures
Up to 40 bar

Temperatures
From -100 to 350 °C

Radial Diffuser Hydraulics (VCTM)

Capacities
Up to 900 m³/h

Pressures
Up to 150 bar

Temperatures
From -100 to 350 °C

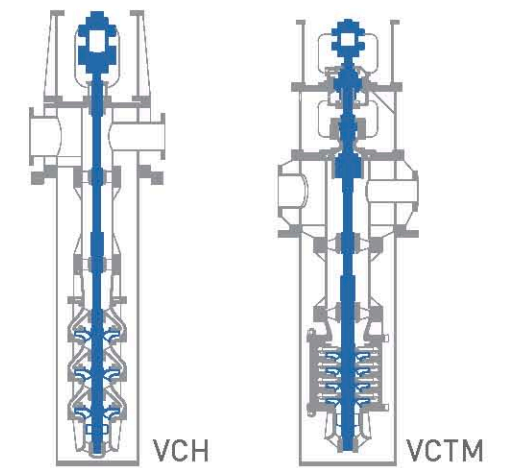

APPLICATIONS

- Cooling Water
- Sea Water and River Water Intake
- Refinery
- Chemical and Petrochemical Industries
- Pipeline and Transfer Service
- Offshore Crude Oil Loading
- Waste Water Treatment

FEATURES AND BENEFITS

- Also manufactured as API 610 / ISO 13709 Type VS1, latest edition.
- Both Rigid and Flexible couplings with or without spacer are available.
- Cast or Fabricated Discharge Heads for various nozzles.
- Precision Machined Heavy Duty Shaft to minimize Shaft Vibration.
- Special Single Suction or Double Suction Impeller is available for lower NPSHR.
- Cartridge Mechanical Seal is available in accordance with API 682.
- Dual Wear Rings are available for enclosed impellers and bowls.
- Suction Bell Bearing is available for shaft stability.

APPLICATIONS

- Condensate and Condensate Extraction
- Hydrocarbon Booster and Transfer
- Pipeline Booster
- Chemical and Petrochemical Industries
- Pipeline and Transfer Service
- Offshore Crude Oil Loading
- Waste Water Treatment
- Cryogenic Services

FEATURES AND BENEFITS

- Also manufactured as API 610 / ISO 13709 Type VS6, latest edition.
- Both Rigid and Flexible couplings with or without spacer are available.
- Cast or Fabricated Discharge Heads for various nozzles.
- Precision Machined Heavy Duty Shaft to minimize Shaft Vibration.
- Inducer, Special Single Suction or Double Suction Impeller for lower NPSHR.
- Cartridge Mechanical Seal is available in accordance with API 682.
- Dual Wear Rings are available for enclosed impellers and bowls.
- Suction Bell Bearing is available for shaft stability.

