



DR117

**1-STAGE REDUCER
WITH REDUCTION RATIO OF 1:17**

감속비 1:17의 1단 감속기



Feature
제품특징



Reduction ratio 1:17

감속비 1:17



1-Stage reduction gear

1단 감속

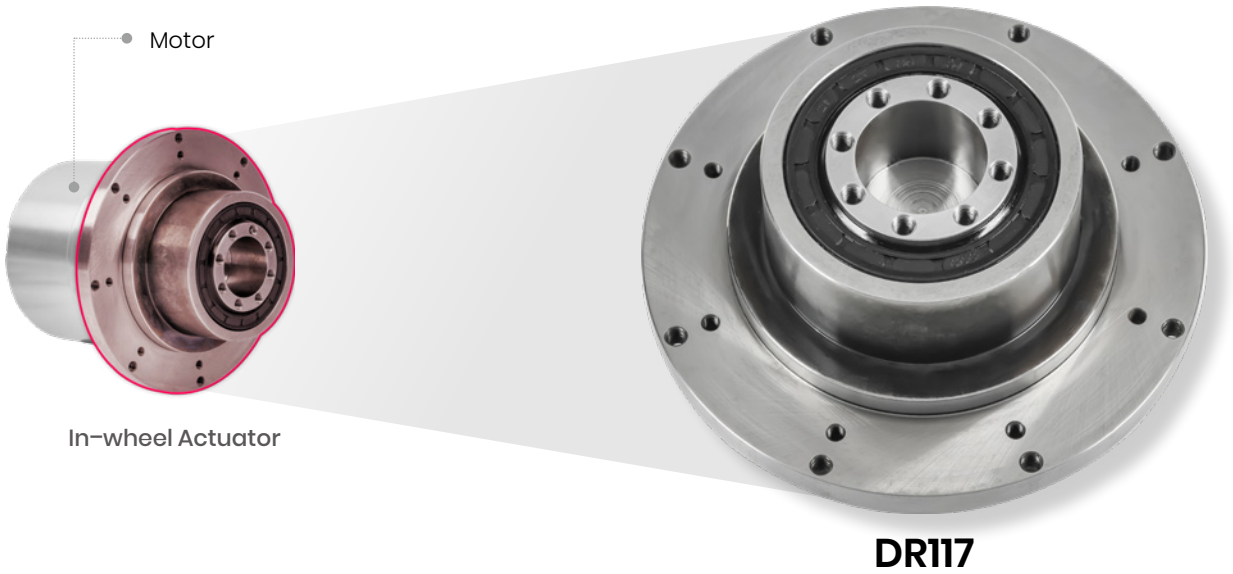

Applicable to in-wheel actuator for AGV & AMR

AGV & AMR 일체형 구동부 적용



Precision : below 10 arcmin.

정밀도 10 arcmin. 이하

Noise : below 60 dB

소음 60 dB 이하

Efficiency : above 90%

효율 90% 이상



DR117 (outer diameter $\phi 117$)
DR117 (외경 $\phi 117$)

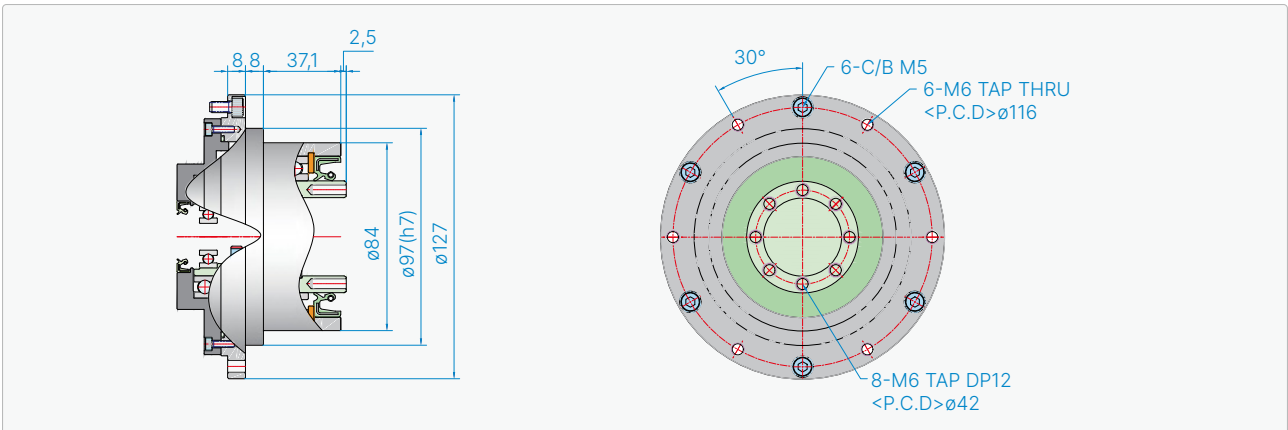

Model	Ratio	2,000 rpm		At start / At stop 기동, 정지 시		Momentary max. 순간 최대		Input rotational speed (r/min) 입력회전수(r/min)	
		Rated torque 정격토크 (Tr)		Allowable acceleration / deceleration torque 가/감속 허용토크		Allowable torque 순간허용토크		Allowable ave. 허용평균	Allowable max. 허용최고
		N·m	Kgf·m	N·m	Kgf·m	N·m	Kgf·m	Grease lubrication 그리스 윤활	
DR117	17	115	11.7	264	26.8	360	36.6	2,000	3,000

※ The above specifications are subject to change for upgrade.
상기 사양은 개선을 위해 변경될 수 있습니다.

※ If you need any other specification like gear ratio of 1:15, 1:20 and 1:25, please feel free to contact us.
감속비 1:15, 1:20, 1:25 등 상기 표와 다른 사양이 필요하실 경우에도 언제든지 연락주시기 바랍니다.



www.drdrive.kr



디알 드라이브 DR DRIVE Co., Ltd.

사무실/공장

경상남도 창원시 마산회원구 자유무역3길 180,
7층 (표준공장 7호동)

기술연구소

경상남도 창원시 마산합포구 진북면 산단2길 132,
연구지원동 307호

Tel. 055-252-8838

Fax. 055-256-8838

Web. www.drdrive.kr

Email. dr@drdrive.kr

Office / Factory

7th floor, 180, Jayumyeok 3-gil,
Masanhoewon-gu, Changwon-si,
Gyeongsangnam-do, Republic of Korea

R&D Center

307, 132, Sandan 2-gil, Jinbuk-myeon,
Masanhappo-gu, Changwon-si,
Gyeongsangnam-do, Republic of Korea

Tel. +82-55-252-8838

Fax. +82-55-256-8838

QR 코드를 스캔하여
DR Drive의 SNS 채널을 만나보세요!

Scan QR codes and
meet DR Drive's social media!

