



mobilio
A.I SENSOR NETWORK

Lite 3

FEATURING 1

4 Types of Models

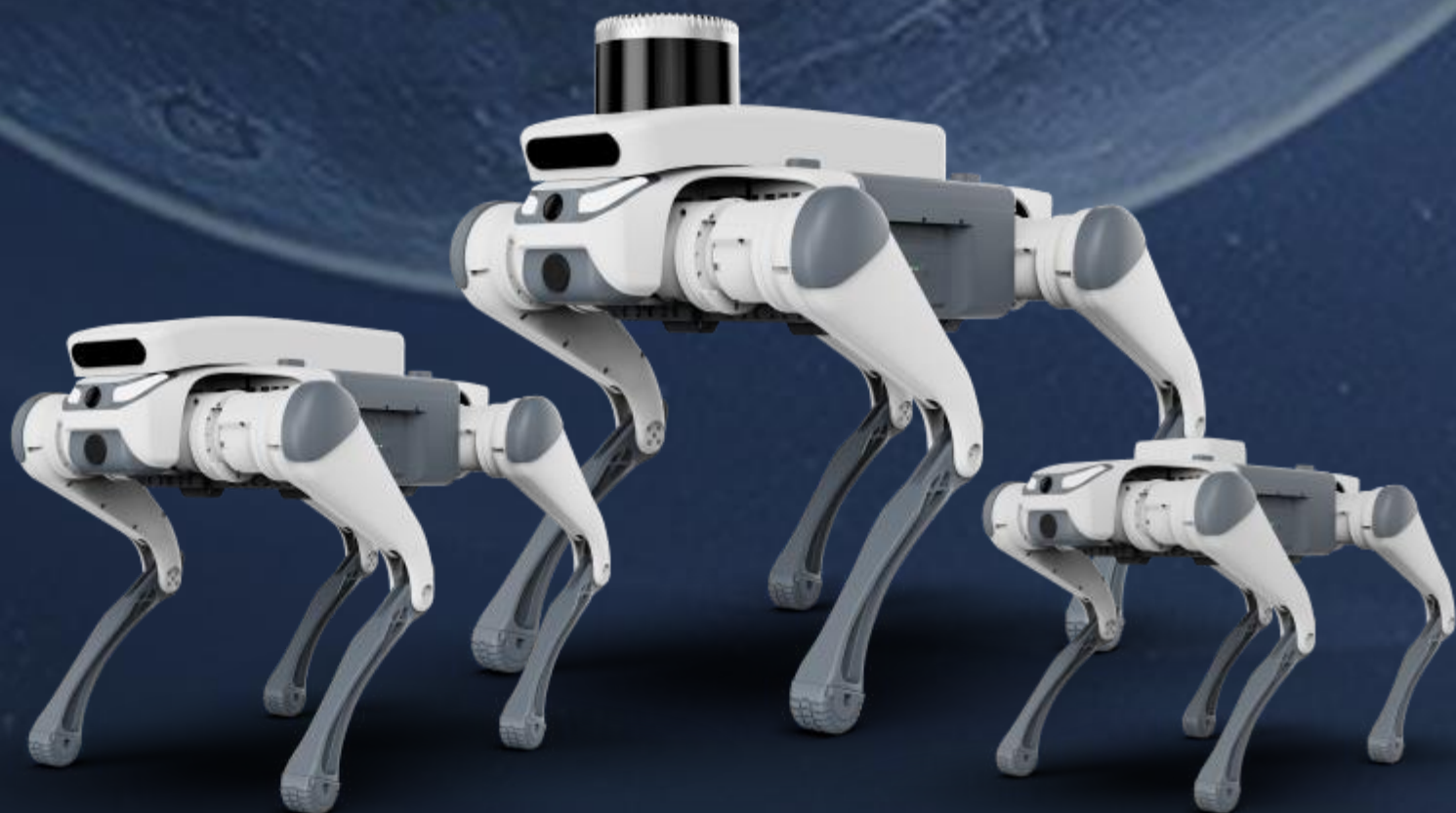

VENTURE / PRO / LIDAR

Provide SDK for motion control algorithm development, source code of some perception development examples, and communication protocol, allowing users to re-develop as needed



BASIC

An entertainment model that can be back-flipped, and unlike other models, not allowing users to re-develop

FEATURING2

New Module

JOINT TORQUE INCREASED

The patented high-torque joint drive module comes equipped with extremely high torque density, response band-width, and reserved transmission efficiency

PERFORMANCE INCREASED

- Increase continuous maximum load by 40% up to 7kg
- Double running hour under the same battery capability
: keep moving for 90min or 4km

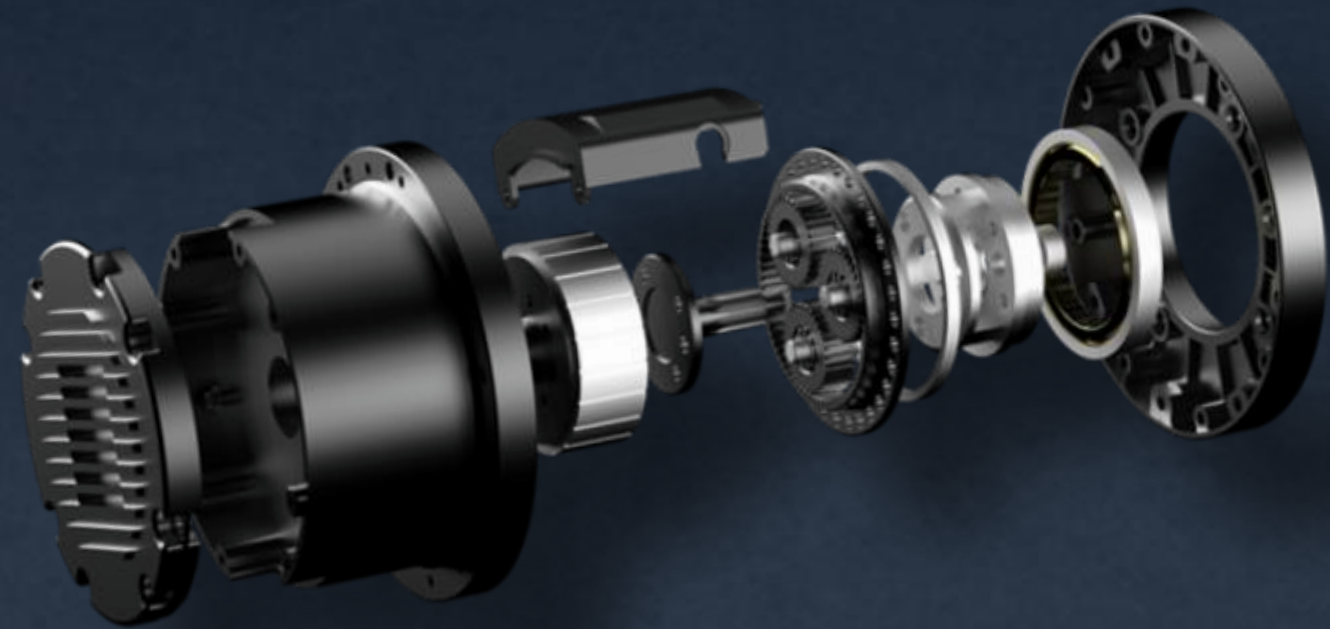

FEATURING3

Gaits and Movements

ALGORITHM UPGRADED WITH MORE AGILITY AND FLEXIBILITY

- The industrial level control system with deeply optimized kernel is deployed for the first-time, which triple the real-time computing power
- The patented algorithm achieve great maneuverability, which realize more complicated movements and overcome more higher obstacles with higher robustness

PERFORMANCE INCREASED

- Climbing capability : Slope 40° , Stairs 15cm
- High jump distance 30cm, Long jump distance 40cm
- Realize front-flip and side-flip, back-flip, twist dance, jump, wave hand, moon walk, self-right
- The control frequency is up to 1k Hz



FEATURING 4

Autonomous Navigation

AUTONOMY CAPABILITY IMPROVED MORE SAFER AND DIVERSE

Both 16 and 32 line lidar can be supported
with latest 3D-SLAM algorithm

PERFORMANCE INCREASED

- Autonomous navigation* and obstacle avoidance / circumvention
- Backward obstacle avoidance
- Object / Human-being identification and following

* These functions are only available for Lidar model





Motion Control



Operate the robot using a joystick or an APP, and the gait/terrain mode can make movements appropriate for the environment

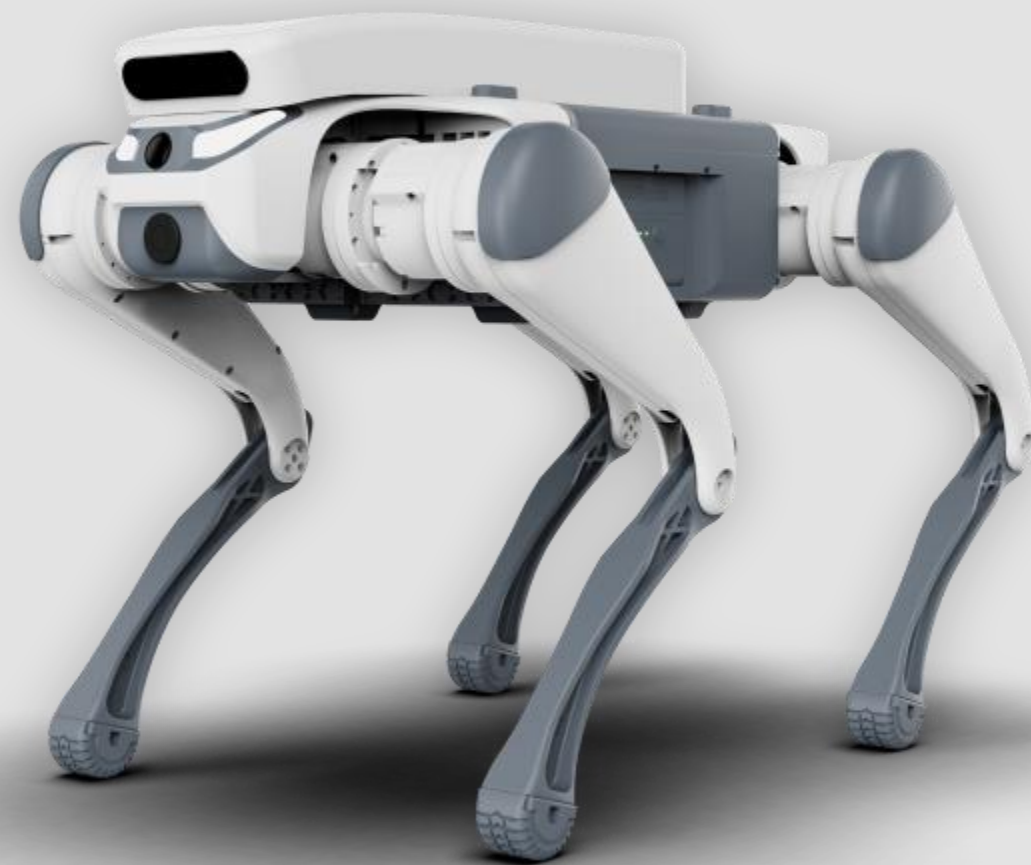

After standing up, you can select gait or terrain options in Move Mode, and push the joysticks to make the robot move

- Gait mode : choose an appropriate body height and velocity
- Terrain mode : choose the mode according to slopes (ex. Stairs, Grasslands, Lower steps, Higher steps)

Control Application

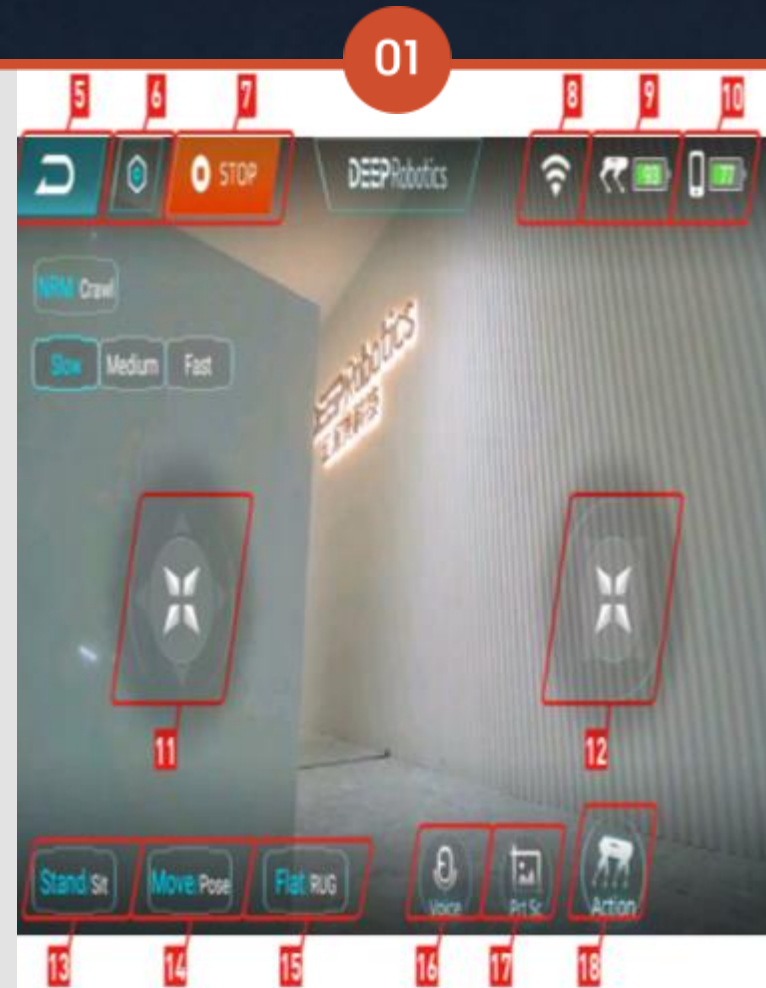

CONTROL PAGE

Control the robot remotely and easily

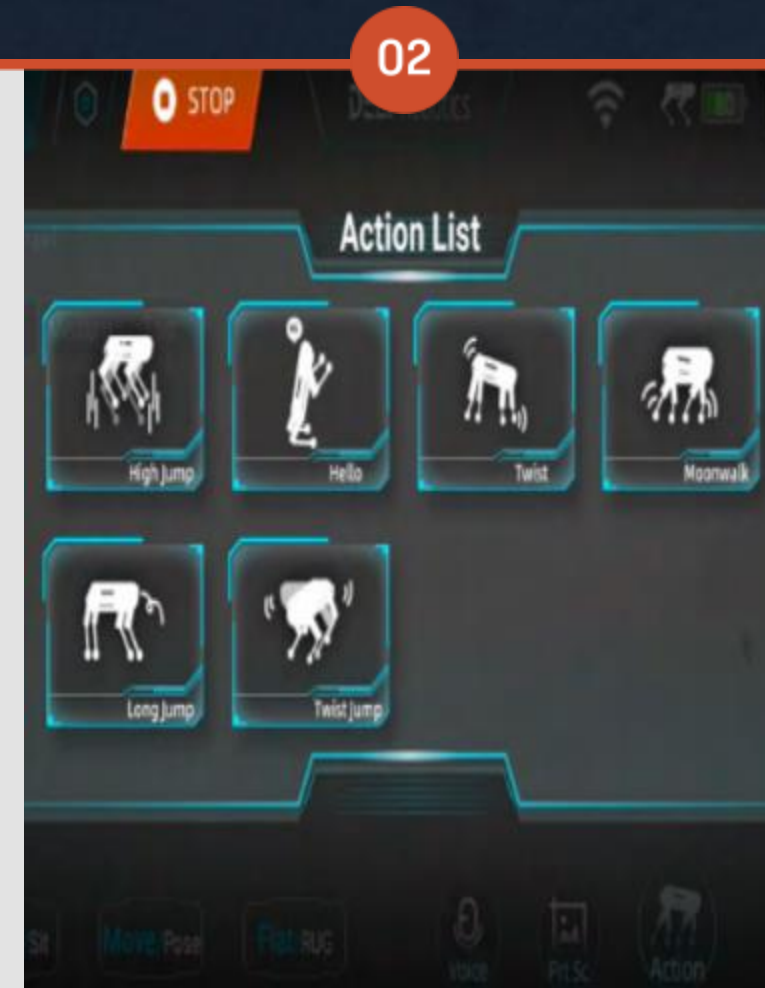

ACTION LIST

Perform actions such as High Jump, Hello, Twist, Moonwalk, Long Jump, Twist Jump



SETTINGS PAGE

Customize the app settings according to needs

OPERATION

Action



To perform Long jump or High jump, make sure that there are no obstacles within 2m in front of the robot

When the robot passes through stairs or slopes, do not stand on the stairs, platforms, or slopes below the robot to avoid potential personal injury when the robot falls

Please avoid using the robot continuously and intensively, otherwise it may cause overheating or damage

Action Option

When the robot is standing or lying still, user can click the 'Action' button to open the action list and select an action

PERFORMANCE INCREASED

- Enhanced FPV video stream with less time delay and higher resolution
- Add the light-language function to know the robot's status in real time



OPERATION

Voice Command

VOICE COMMAND & ACTION



Click the 'Voice' button at the bottom of the Control Page and say the corresponding command, and the robot will execute the corresponding action

Command	Action
stand up	Stand up
get down	Get down
go forward	Walk forward for 5 seconds
go backward	Walk backward for 5 seconds
go left	Walk to the left for 5 seconds
go right	Walk to the right for 5 seconds
stop	Stop walking
look up	Raise the head
look down	Bow the head
look left	Turn head to the left
look right	Turn head to the right
turn left	Turn 90° to the left and stop
turn right	Turn 90° to the right and stop
turn around	Turn backwards 180° and stop
say hello	Greet

DETAILED INFORMATION

Part Name

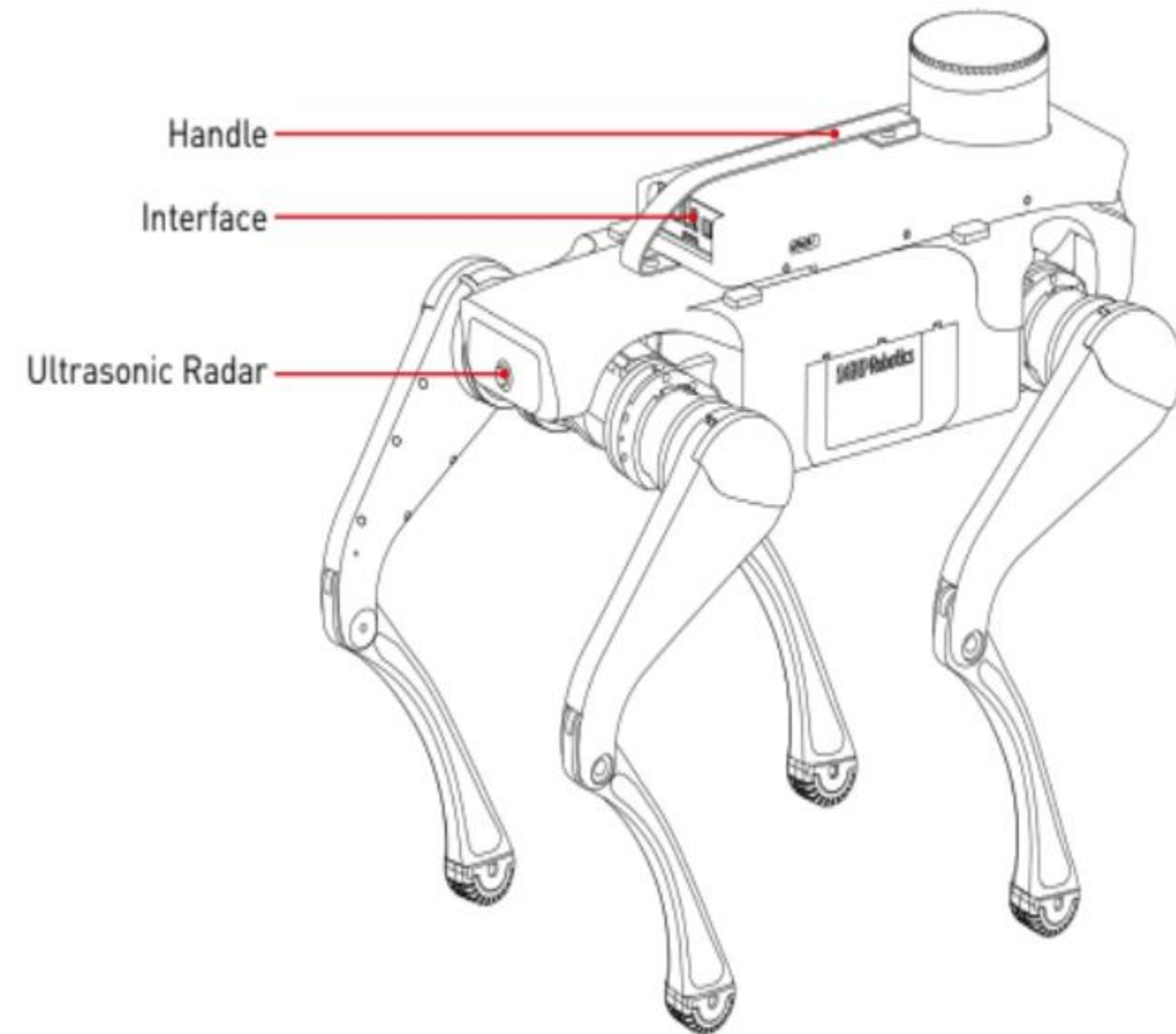
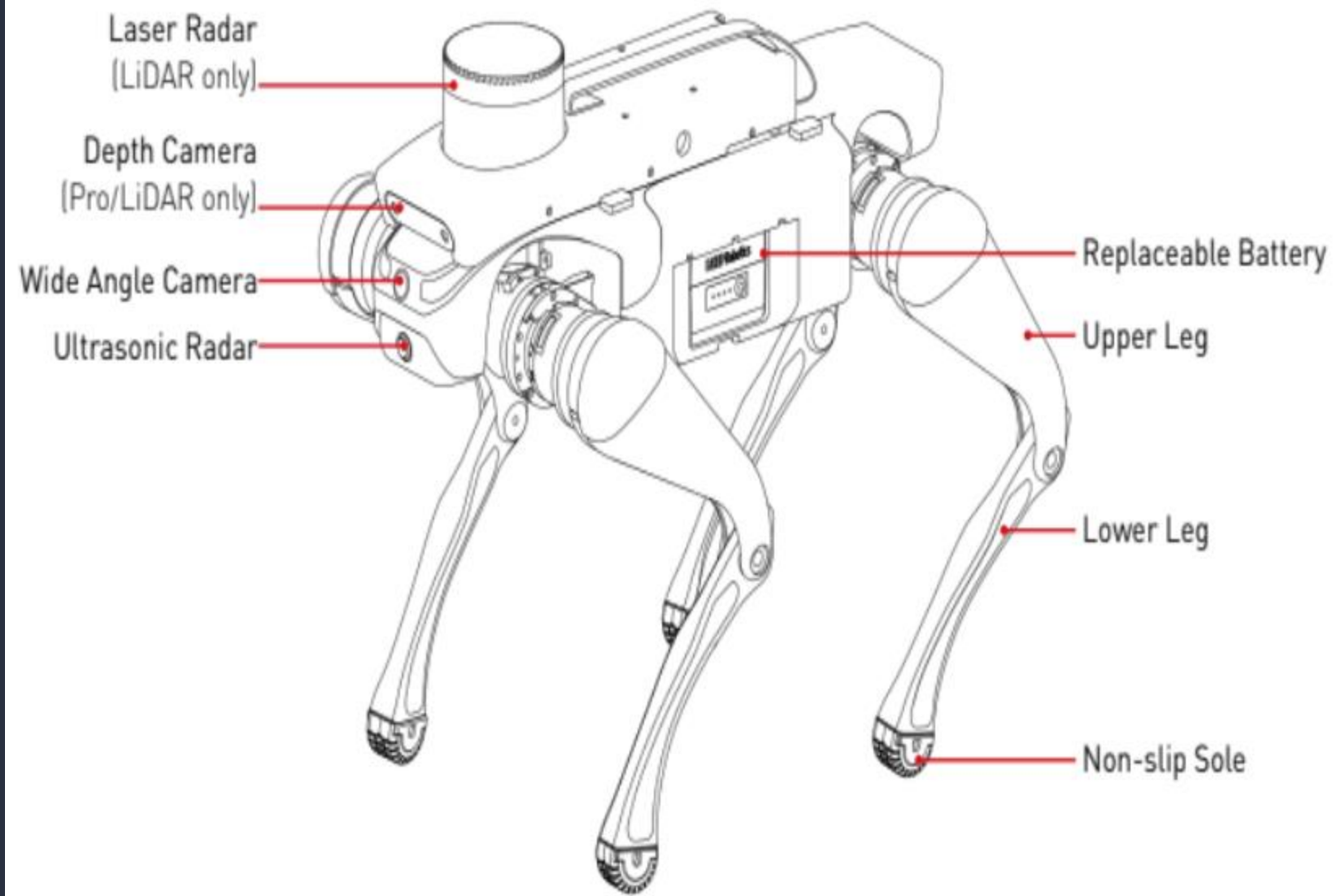

DETAILED INFORMATION

Secondary development difference

Parameter	Lite 3	Lite 3 V	Lite 3 P	Lite 3 L
Interface	○	Power charging x 1 Ethernet x 2 5V x 1 12V x 1 24V x 1	Power charging x 1 USB 3.0 x 1 HDMI x 1 Ethernet x 1 5V x 1 24V x 1	Power charging x 1 USB 3.0 x 1 HDMI x 1 Ethernet x 1 5V x 1 24V x 1
Secondary development	○	Front & rear stopping obstacles; Identify & Following	Forward Detour; Front & rear stopping obstacles; Identify & Following	3D SLAM(open Source Algorithm) Forward Detour; Front & rear stopping obstacles; Identify & Following

Hardware	Lite 3	Lite 3 V	Lite 3 P	Lite 3 L
Ultrasonic Radar	x 2	x 2	x 2	x 2
Wide angle Camera	x 1 1920 x 1080 @30fps	x 1 1920 x 1080 @30fps	x 1 1920 x 1080 @30fps	x 1 1920 x 1080 @30fps
AI Host	○	○	Nvidia Jetson Xavier NX	Nvidia Jetson Xavier NX
Depth Camera	○	○	Intel RealSense D435i x 1	Intel RealSense D435i x 1
Lidar	○	○	○	Leisheng C 16 x 1

DETAILED INFORMATION

Version function difference

Parameter	Lite 3	Lite 3 V	Lite 3 P	Lite 3 L
Real time Transmission	●	●	●	●
Forward Detour	●	●	●	●
Body Tracking	○	○	●	●
Front and Rear Obstacle Detection	○	○	●	●
Autonomous Navigation	○	○	○	●



ROBOQ-LITE 3

VENTURE

A

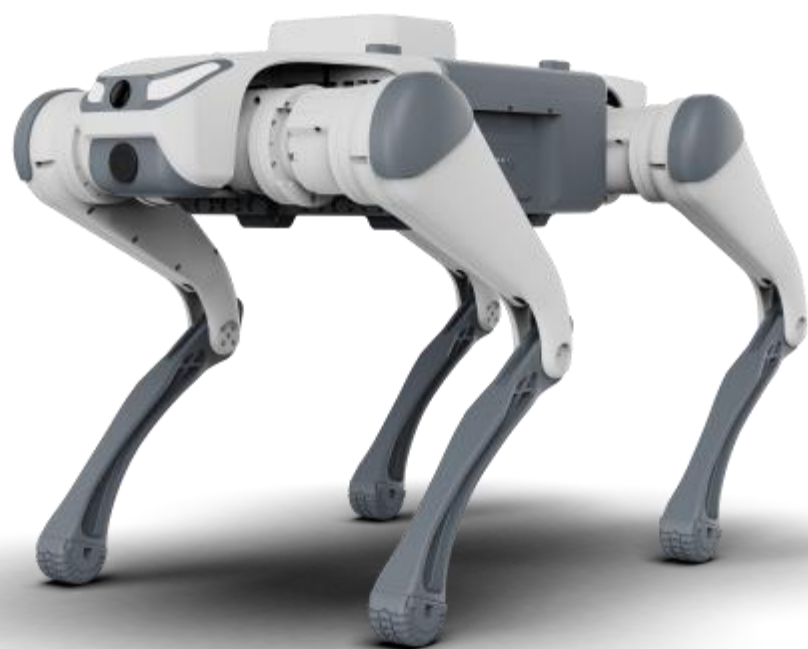

Wide Angle Camera, Ultrasonic Radar

DETAIL

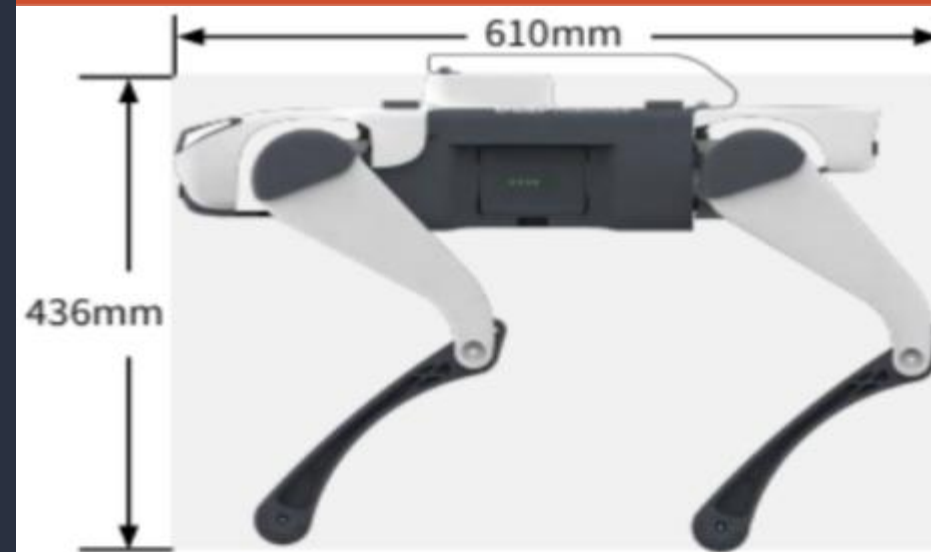

SIZE

370 x 610 x 436 (mm)

INTERFACE

Ethernet Input
(5V / 12V / 24V)

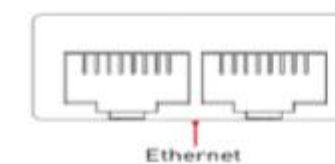
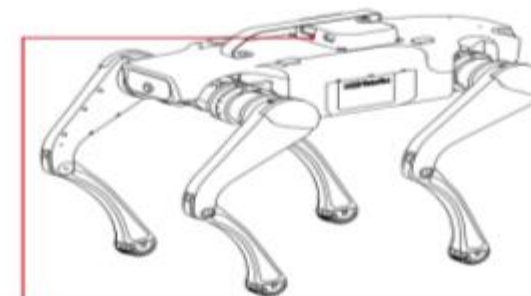

Ethernet

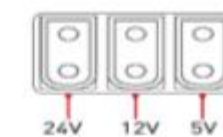

24V 12V 5V



PERCEPTION

- Front&Rear Auto-stop
- Object following

ROBOQ-LITE3

PROFESSION

B

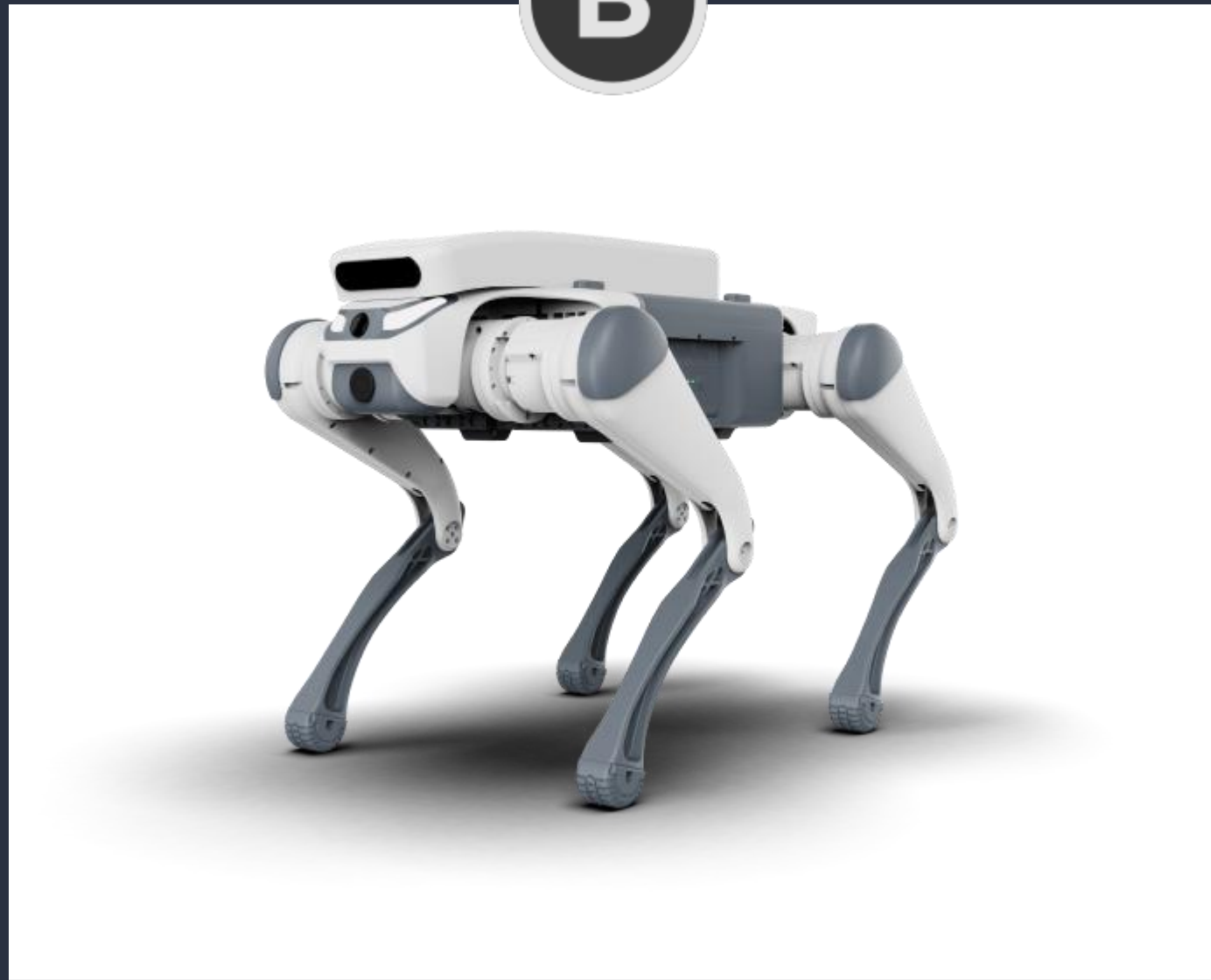

Wide Angle Camera, Ultrasonic Radar,
Depth Camera, AI Computer

DETAIL



SIZE

370 x 610 x 445 (mm)

INTERFACE

Type - C; USB3.0; HDMI;
Ethernet Input (5V / 24V)

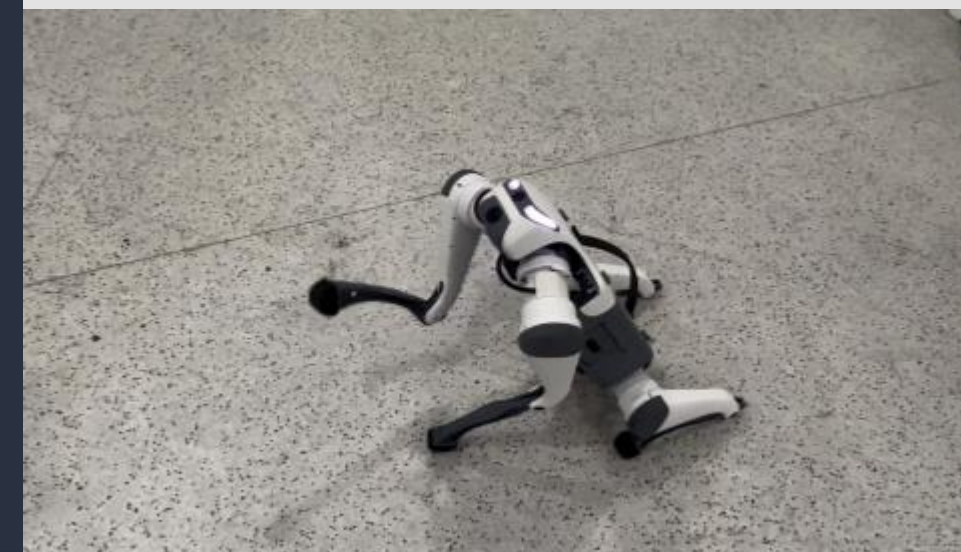
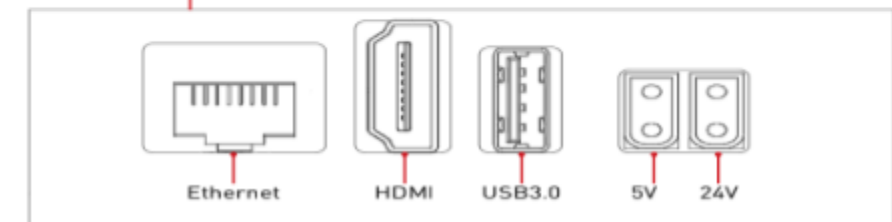
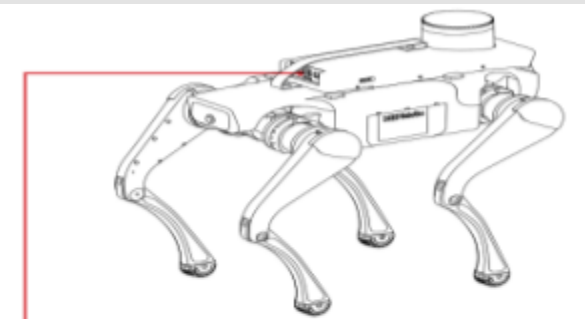

PERCEPTION

- Front&Rear Auto-stop
- Object following
- Obstacle avoidance

ROBOQ-LITE3 LIDAR

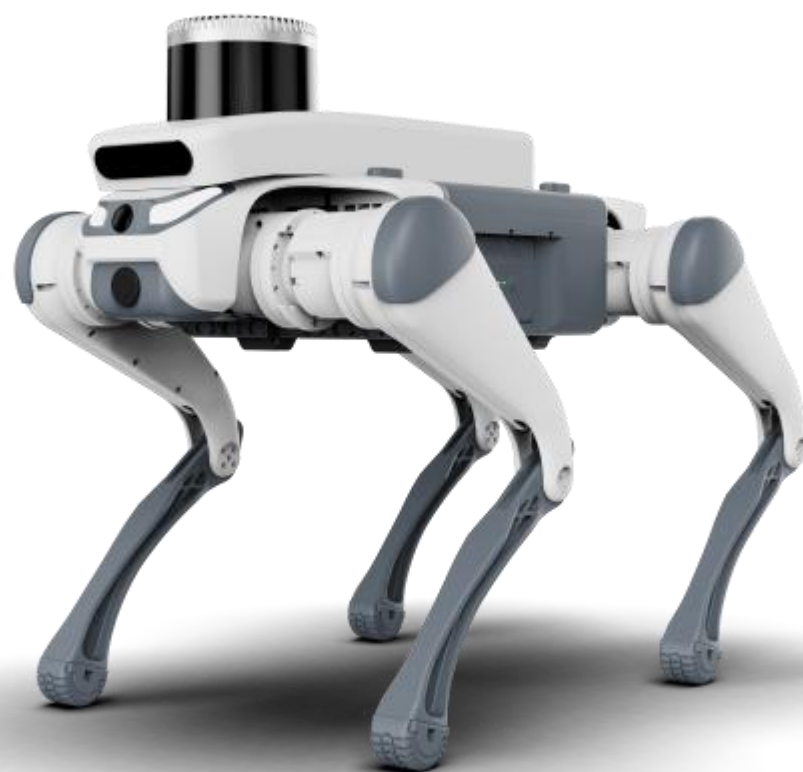

Wide Angle Camera, Ultrasonic Radar,
Depth Camera, LiDAR, AI Computer

DETAIL



SIZE

370 x 610 x 503 (mm)

INTERFACE

Type - C; USB3.0; HDMI;
Ethernet Input (5V / 24V)

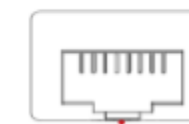
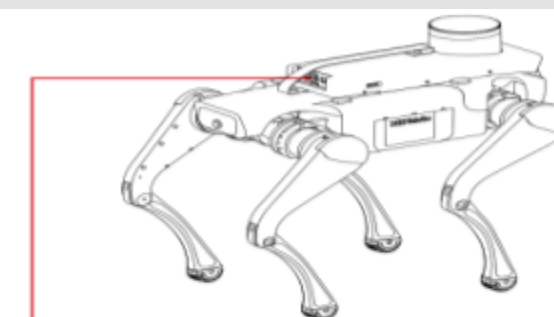

Ethernet



HDMI



USB3.0



5V



24V



PERCEPTION

- Front&Rear Auto-stop
- Object following
- Obstacle avoidance
- 3D SLAM

DETAILED INFORMATION

Specification

ITEM \ MODEL	Explore	Profession	LiDAR
STANDING SIZE	610*370*445mm	610*370*445mm	610*370*445mm
NET WEIGHT (with battery)	12.2kg	12.7kg	13.7kg
DURATION	1.5h~2h	1.5h~2h	1.5h~2h
DISTANCE	4km	3.4km	2.7km
SLOPE	40°	40°	40°
STAIRS' HEIGHT	15cm	15cm	15cm
PAYLOAD (continuous)	7kg	6.5kg	5kg
PERCEPTION	<ul style="list-style-type: none"> • front & rear auto-stop • object following 	<ul style="list-style-type: none"> • front & rear auto-stop • object following • obstacle avoidance 	<ul style="list-style-type: none"> • front & rear auto-stop • object following • obstacle avoidance • 3D SLAM
INTERFACE	Ethernet Input (5V/12V/24V)	USB3.0; HDMI; Ethernet; Input (5V/24V)	

CONTACT

CALL

+82-31-713-2030

EMAIL

sales@mobilio.io

HOMEPAGE

<https://www.mobilio.io>

ADDRESS

(HQ) #804, Tower-A, 46, Dallaenae-ro,
Sujeong-gu, Seongnam-si, Gyeonggi-do

(R&D) #504, INSTA 1, 204, Convensia-daero,
Yeonsu-gu, Incheon



AI Technology for Human Safety